

Design and Fabrication of Solar Based E-Jacket for Soldiers

¹Rahul Khairamode, ²Rahul Khangoukar, ³Rutik Patil, ⁴Vinayak Nagarale,

⁵Prof.Rekha Malipatil,

⁶Dr.Supanna S. Shirguppe

^{1,2,3,4}Student, ⁵AssistantProfessor, ⁶HOD

¹DepartmentofElectrical and Electronics Engineering,

¹S.G. BalekundriInstitute of Technology,Belagavi,Karnataka,India

Abstract: In every year we are facing several patterns of climates, the summer season, rainy season and winter seasons are the main. Temperatures that are very high and very low are both hazardous to health. Too much exposure to heat is called heat stress as well as excessive too much cold is called cold stress. At a very high temperature the most serious problem is heatstroke. In extreme cold, the most serious trouble is the risk of dehydration or dangerously cold bodies. Here we will design an E-Jacket for better protection for people living in high outlook situation. GPS module also used in this jacket for spot the location.

Keywords: Heart rate sensor with spO2, temperature Sensor, longitude and latitude sensor, heating and cooling effect

I. INTRODUCTION

Soldiers are the important role in the defence of a country. Soldiers will be constantly on duty in extreme weather conditions. While keeping our nation safe, they are facing problems in extreme changing weather conditions. Each temperature, especially hot and cold, presents a physical risk. In a very hot environment, the hardest challenge is heatstroke. In extremely cold temperatures, a critical situation is a risk of hypothermia or a very cold frame is at risk. In this mission, we have developed an electronic uniform to provide better security for infantry soldiers operating in extreme weather conditions. This challenge offers heat and cool mode. By choosing operating way, the switches control heating/cooling of the E-Jacket. This solar based E-Jacket for soldiers will assist us to give warm and cool effect, so that fighters can survive any form of exterior surroundings.

II. LITERATURE SURVEY

1. “SOLAR BASED E-UNIFORM FOR SOLDIERS-USED FOR TEMPERATURE CONTROL AND TRACKING “

Author: - M. Sivalingamaiah, E. Satheshkumar, M. Vijaya Lakshmi

Solar powered electronic uniforms provide a safeguard for the servicemen who are survive in greatest climates. Photovoltaic cells are used to generate the electricity for E-Jacket. The battery is used to store the energy. You can also use a regular battery charger to charge the battery.

2. “SOLAR BASED E-UNIFORM FOR SOLDIERS”

Author: - Asist. prof. Sridevi S.H, Mr Amit Dobade, Mr. Rohit Phulmali, Mr. Rahul Sinare

Solar based E-Uniforms provide better protection for soldiers working in extreme weather conditions. Solar panels are used to power up the internal circuits of the uniform. Energy is stored by using a 12V DC lead-acid battery. Regular batteries can also be used as charger. The LPC2148 microcontroller controls all the functions. A voltage sampler is interfaced with the system using an ADC to obtain the voltage generated from the battery as displayed on the 16X2 LCD. In this article, we have designed an electronic military uniform that provides better protection for soldiers working in extreme weather conditions. This uniform will greatly facilitate the work of the soldier to work in any kind of environment.

III. COMPONENTS

1. NodeMCU ESP8266

Esp8266 is a cheap microcontroller. It can give any microcontroller access to your Wi-Fi network. The ESP8266 can work in 3 unique modes: wireless station, wireless access point and both at the same time. The nodemcu can be controlled from the local Wi-Fi community like mobile.

2. Solar panel (photovoltaic cell)

Photo voltaic cell is a device that absorbs sunlight and converts light energy into electrical energy. Mainly solar panels divided into three types; polycrystalline, monocrystalline and thin-film.

3 LM35

The LM35 is an integrated analog temperature sensor that emits its power equivalent to Degree Centigrade. The LM35 sensor does not require external measurement or cutting to provide normal accuracy. The sensitivity of the LM35 is 10 mV / degree Celsius. As the temperature rises, the output voltage also increases. For example, power 260 mV at 26 ° C. This is a 3-terminal sensor used to measure the area temperature from -50 ° C to 140 ° C.

4 MAX 30100

MAX30100 is a blood oxygen level and heart beat sensor. which senses oxygen level and heart beating using two IR and red LEDs, the red light is a photo electric detector, better optics and less noise analog pulsation. infrared light is first transmitted through the infrared sensor at the tip of the finger, then reflected the light onto a red light or photodiode sensor and converted to a suitable signal by signal conditioning.

5 Thermoelectric coupler (peltier plate)

Peltier modules include outside ceramic plates separated through semiconductor wafers. one of the plates absorbs warmth (cool) and the alternative plate dissolves heats up (hot) as it is distributed via semiconductor fluids.

The supply is implemented to

all linked conductors to provide current. When the current passes via a junction of conductors, the warmth is eliminated from one region after which cooled. heat is applied to the junction of the region. the key Peltier impact effect is cooling.

6 Battery

Battery which converts chemical energy into electricity by an electrochemical oxidation – reduction (oxidation – reduction) method. It is used as a backup power for the circuit. SI unit of battery is Ah (Ampere – hour). In batteries, there are four kinds: lead–acid batteries, nickel–cadmium batteries, nickel–metal hydride batteries, lithium–ion batteries.

IV. METHODOLOGY

We use solar panels to generate the needed energy and rechargeable batteries to store the energy. In this project, we design and develop an E-Jacket for soldiers to avoid the problems they face due to extreme hot and cold weather conditions during their working time. We have designed two mode switching operations. Heat and cool operations. Peltier plate provides heat and cool effects respectively. The heating and cooling effect is useful to provide a cool and warm effect inside the E-Jacket. This makes it possible for the soldier to endure all kinds of outdoor environments. In this project, we are using a pulse oximeter that measures pulse and blood pressure. Also using GPS to know the exact location of soldiers, LM35 is used to know the surrounding temperature. LCD display shows battery voltage, heart rate, blood pressure, location and temperature.

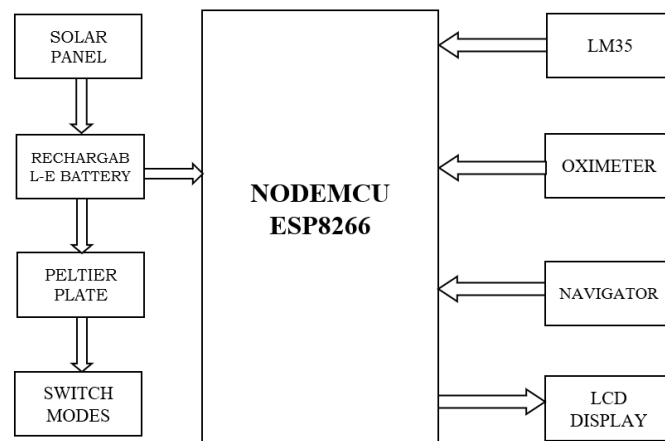

BLOCK DIAGRAM

V. CALCULATION

- **Detailed electricity consumption.**

$(40W \times 5h) = 200 \text{ Wh/day}$

Total energy of solar cells needed = $200 \times 1.3 = 260 \text{ Wh/day}$

1.3 is the energy loss

- **Size PV panels**

Overall Wp of PV panel's required power = $260/4.5 = 57.7 \text{ Wp}$.

Number of PV panels required = $57.7/60 = 0.96$ modules

*Actual requirement = 1 module of 60W

*4.5 is solar panel generation factor Heaven for India

- **Inverter size**

Watt total of all devices = $40w \times 5 = 200W$

Inverter have to viewed 25-30% larger size for safety reasons.

The capacity of the inverter have to be about 250W or more.

- **Battery Size**

Gross usage = $(40W \times 5h)$

Battery nominal voltage = 12V

Battery life = 3 days

Battery capacity = $\frac{[40W \times 5\text{hours}] \times 3}{(0.85 \times 0.6 \times 12)}$

Total Amphours required 98.03 Ah

So the battery have to be 12V 100 Ah.

- **PV Module Specification**

PV module specification

$P_m = 60Wp$

$V_m = 17.3Vdc$

$I_m = 3.48A$

$V_{oc} = 21.6 \text{ A}$

$I_{sc} = 3.66A$

Solar Charge Controller rating = $(2 \text{ Modules} \times 3.66A) \times 1.3 = 4.8A$

the Charge Controller of photovoltaic cell have to be rated 6A 12V or more.

VI. RESULT

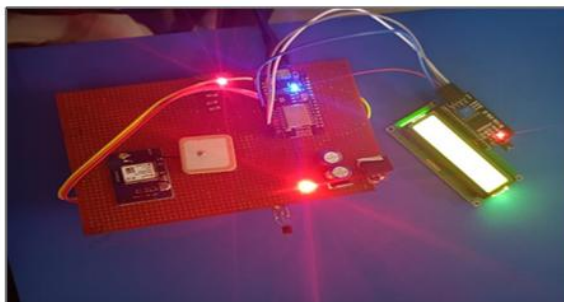

SOFTWARE KIT



VII.CONCLUSION

The solar based E-jacket very useful for soldiers especially, like different weather conditions for soldiers and civilians. And it useful to update the soldier's health status.

FUTURE SCOPE

In the future we can change the type of solar panel type and we can add cooling effect and rain sensor etc. to achieve higher efficiency of E-Jacket. Then we can use it for all weather conditions. The E-Jacket will be helpful to protect ourselves from rapid changing climate.

REFERENCE

- [1]. Maneesh Kumar Srivastav¹, Sandeep Bhatia², Mudit Dwivedi³, Kritika Pandey⁴, Kollur Ragini⁵, "Solar based E-Uniform for Soldiers". ISSN: 2321-9653; IC Value: 45.98; Impact Factor: 7.429. Volume 8 Issue V May 2020.
- [2]. Felix Felgner, Luka Exel, Marco Nesarajah, and Geogr Frey, "Component- Oriented Modelling of Thermo-electric Devices for energy system Design", IEEE Transactions on Industrial Electronics, Vol. 61, No, 3, pp.1301-1307, March 2014.
- [3]. S. Rahmam, M. A.Khallat, and B. H. Chowdhury, "A discussion on diversity in the applications of photovoltaic system", "IEEE Trans.Energy Conversion, vol. 3, PP. 738- 746, Dec. 1988.
- [4]. Adarsh K S, Arun Dinesh, JyothyElizebeth D: "Solar Based E-Uniform for Soldier's Who Work at Extreme Temperature Regions", International Journal of Engineering Research and general Science Volume 3, May-June, 2015, pp.993-998.